



The Ultimate in Fall Protection

**User Instruction Manual**  
Mobile Rope Grab Models:  
5000335C, 5000336C

**User Instruction Manual 5000335C, 5000336C Mobile Rope Grab**

*This manual is intended to meet the Manufacturer’s Instructions as required by CSA Z259.2.5.  
and should be used as part of the employee training program.*

**WARNING:** This product is part of a personal fall arrest or restraint system. The user must read and follow the manufacturer’s instructions for each component or part of the complete system. These instructions must be provided to the user of this equipment. The user must read and understand these instructions or have them explained to them before using this equipment. Manufacturer’s instructions must be followed for proper use and maintenance of this product. Alterations or misuse of this product or failure to follow instructions may result in serious injury or death.

**IMPORTANT:** If you have questions on the use, care, or suitability of this equipment for your application, contact Capital Safety.

**IMPORTANT:** Before using this equipment, record the product identification information from the ID label in the Inspection and Maintenance Log at the back of this manual.

**DESCRIPTION:**

The DBI/Sala Mobile Rope Grab key components are depicted below in Figure 1. The Mobile Rope grab provides a portable lanyard connection point on a 5/8” diameter rope lifeline. The rope grab is designed to automatically follow the user and may be detached anywhere along the lifeline.

**Figure 1 – 5/8” Mobile Rope Grab**

A	Handle Spring
B	Detent Pin
C	Lanyard Connection Handle
D	Enclosure
E	Hinge Rope Retainer
F	ID Label
G	Locking Roller
H	Gravity Lock
I	Roller Cam
J	Warning Label

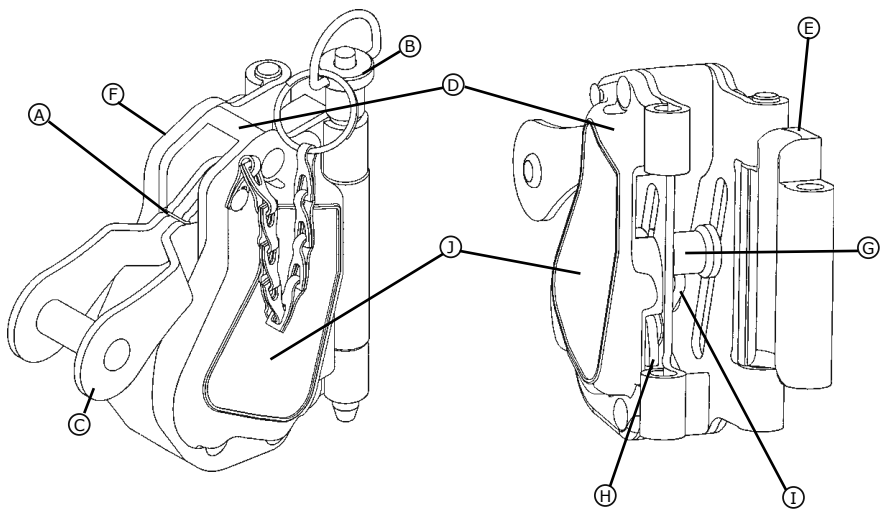

## 1.0 APPLICATIONS

**1.1 PURPOSE:** DBI/SALA rope grab fall arresters are intended to be used as part of a personal fall arrest or restraint system. Applications for this type of product include inspection work, construction and demolition, maintenance, oil production, window washing, and other activities where there exists the need for fall arrest or restraint with vertical or sloped mobility. See Figures 2 & 3. The following definitions describe these applications:

**A. FALL ARREST:** The rope grab is used as part of a complete fall arrest system. Such systems generally include a lifeline, rope grab, energy absorbing lanyard, and full body harness (body support). Applications include: protection of a worker on scaffolding, powered platforms, or riding a boatswain's chair. Maximum permissible free fall is 1.8 m (5.9 feet). The rope grab must be used with an E4 or E6 energy absorbing lanyard less than .75 meter (30 inches) in length to meet CSA Z259.2.5 fall arrester requirements. Do not use rope grab without an energy absorber.

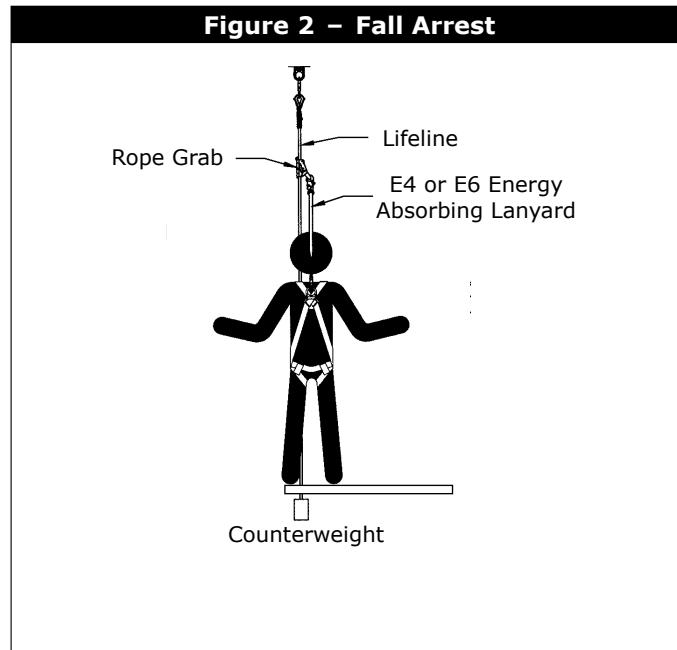

**B. RESTRAINT:** The rope grab is used in combination with a lifeline, lanyard or connector, and body support to restrain the user from reaching a hazard (sloped or leading edge roof work). No vertical free fall is possible.

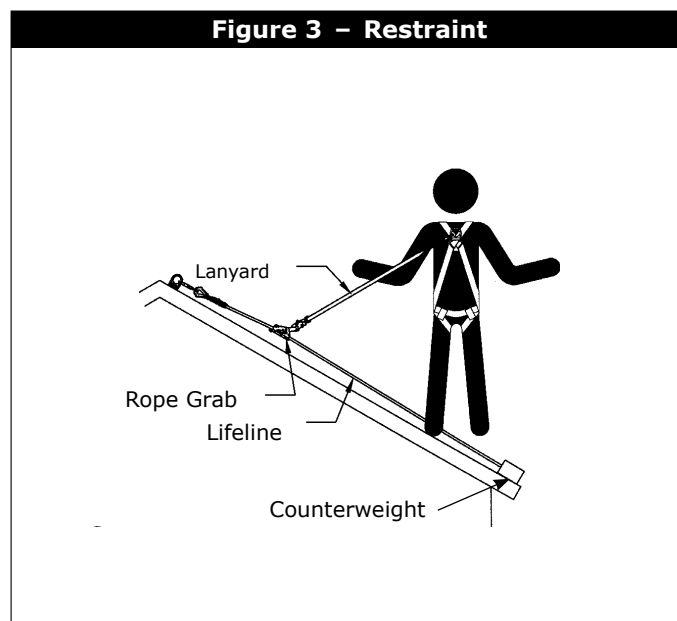

**1.2 LIMITATIONS:** Always consider the following limitations and requirements when installing or using this equipment.

**A. CAPACITY:** This equipment is designed for use by persons with a combined weight (person, clothing, tools, etc.) of 45kg (100 lbs) to 115 Kg (254 lbs) when using an E4 energy absorbing lanyard or 90 kg (200 lbs) to 175 kg (386 lbs) when using an E6 energy absorbing lanyard. NOTE: No more than one person may be attached to a single lifeline.

- B. FREE FALL:** Restraint systems must be rigged such that there is no possible vertical free fall. Personal fall arrest systems must be used with an E4 or E6 energy absorbing lanyard and the system must be rigged to limit the free fall to 1.8 m (5.9 feet) or less per (CSA Z259.2.5). See associated connecting subsystem manufacturer's instructions for additional information.
- C. FALL CLEARANCE:** Make certain that enough clearance exists in your fall path to prevent striking an object. The amount of clearance required is dependent upon the type of connecting subsystem used (lanyard, lifeline), the anchorage location, and the amount of stretch in the lifeline, free fall distance, and deceleration distance. See Section 3.2 and Figure 7 for more information on determining fall clearance.
- D. CORROSION:** Do not leave this equipment for long periods in environments where corrosion of metal parts could take place as a result of vapors from organic materials. Sewage and fertilizer plants, for example, have high concentrations of ammonia. Use near seawater or other corrosive environments may require more frequent inspections or servicing to ensure corrosion damage is not affecting the performance of the product.
- E. CHEMICAL HAZARDS:** Solutions containing acids, alkali, or other caustic chemicals, especially at elevated temperatures, may cause damage to this equipment. When working with such chemicals, frequent inspection of this equipment must be performed. Consult DBI/SALA if doubt exists concerning using this equipment around chemical hazards.
- F. HEAT:** This equipment is not designed for use in high temperature environments. Protection should be provided for this equipment when used near welding, metal cutting, or similar activities. Hot sparks may burn or damage this equipment. Consult DBI/SALA for details on high temperature environments.
- G. ELECTRICAL HAZARDS:** Due to the possibility of electric current flowing through this equipment or connecting components, use extreme caution when working near high voltage power lines.
- H. COMPONENT COMPATIBILITY:** The rope grab addressed by these instructions is intended for use with DBI/SALA lifelines and lifeline subsystems only. Consult DBI/SALA if you are considering using this equipment with other lifelines or lifeline subsystems. See Section 2.0.
- I. TRAINING:** This equipment is to be used by persons who have been properly trained in its correct application and use.

**1.3 REQUIREMENTS:** Refer to applicable local, state, and federal requirements governing this equipment for more information on rope grabs and associated system components, including; CSA Z259.2.5.

**1.4 RESCUE PLAN:** When using this equipment, the employer must have a rescue plan and the means on hand to implement the rescue. The plan must also be communicated to the plan users, authorized personnel and the rescuers as well.

**1.5 INSPECTION BEFORE USE:** The rope grab must be inspected according to procedures in Section 5 of this manual.

## **2.0 SYSTEM REQUIREMENTS**

**2.1 COMPATIBILITY OF COMPONENTS:** Capital Safety equipment is designed for use with Capital Safety approved components and subsystems only. Substitutions or replacements made with non-approved components or subsystems may jeopardize compatibility of equipment and may affect the safety and reliability of the complete system.

**2.2 COMPATIBILITY OF CONNECTORS:** Connectors are considered to be compatible with connecting elements when they have been designed to work together in such a way that their sizes and shapes do not cause their gate mechanisms to inadvertently open regardless of how they become oriented. Contact Capital Safety if you have any questions about compatibility.

Connectors (hooks, carabiners, and D-rings) must be capable of supporting at least 22.2 kN (5,000 lbs.). Connectors must be compatible with the anchorage or other system components. Do not use equipment that is not compatible. Non-compatible connectors may unintentionally disengage. (See Figure 4.) Connectors must be compatible in size, shape, and strength. If the connecting element to which a snap hook (shown) or carabiner attaches is undersized or irregular in shape, a situation could occur where the connecting element applies a force to the gate of the snap hook or carabiner. This force may cause the gate (of either a self-locking or a non-locking snap hook) to open, allowing the snap hook or carabiner to disengage from the connecting point. Self-locking snap hooks and carabiners are required.

**Figure 4 – Unintentional Disengagement**

If the connecting element to which a snap hook (shown) or carabiner attaches is undersized or irregular in shape, a situation could occur where the connecting element applies a force to the gate of the snap hook or carabiner. This force may cause the gate (of either a self-locking or a non-locking snap hook) to open, allowing the snap hook or carabiner to disengage from the connecting point.

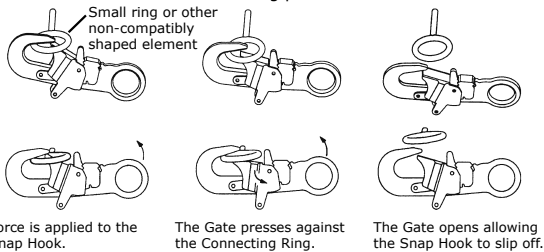

**Figure 5 – Inappropriate Connections**

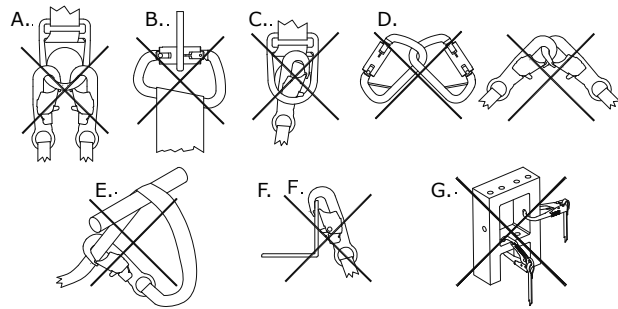

**2.3 MAKING CONNECTIONS:** Use only self-locking snap hooks and carabiners with this equipment. Use only connectors that are suitable to each application. Ensure all connections are compatible in size, shape and strength. Do not use equipment that is not compatible. Ensure all connectors are fully closed and locked.

Capital Safety connectors (snap hooks and carabiners) are designed to be used only as specified in each product's user's instructions. See Figure 5 for inappropriate connections. Capital Safety snap hooks and carabiners should not be connected:

- A. To a D-ring to which another connector is attached.
- B. In a manner that would result in a load on the gate.

**CAUTION:** Large throat snap hooks should not be connected to standard size D-rings or similar objects which will result in a load on the gate if the hook or D-ring twists or rotates.

- C. In a false engagement, where features that protrude from the snap hook or carabiner catch on the anchor, and without visual confirmation seems to be fully engaged to the anchor point.
- D. To each other.
- E. Directly to webbing or rope lanyard or tie-back (unless the manufacturer's instructions for both the lanyard and connector specifically allows such a connection).
- F. To any object which is shaped or dimensioned such that the snap hook or carabiner will not close and lock, or that roll-out could occur.
- G. In a manner that does not allow the connector to align properly while under load.

**2.4 ANCHORAGE STRENGTH:** Anchorages selected for use with the rope grab must have a strength capable of sustaining the static load requirements of the intended fall protection application:

- A. **FALL ARREST:** Anchorages selected for fall arrest systems shall have a strength capable of sustaining static loads applied in the directions permitted by the system of at least:
  1. 22.2 kN (5,000 lbs) for non-certified anchorages, or
  2. Two times the maximum average arresting force for certified anchorages.

When more than one fall arrest system is attached to an anchorage, the strengths set forth in (1) and (2) above shall be multiplied by the number of systems attached to the anchorage.

**WARNING:** Tip-over anchors will have large anchor deformation that will affect system performance. This may also increase the required fall clearance below the system. This factor must be considered and it may be necessary to increase fall clearance in order to prevent serious injury or death to the user.

**FROM OSHA 1926.500 AND 1910.66:** Anchorages used for attachment of PFAS shall be independent of any anchorage being used to support or suspend platforms, and capable of supporting at least 22.2 kN (5,000 lbs) per user attached, or be designed, installed, and used as part of a complete PFAS which maintains a safety factor of at least two, and is supervised by a qualified person.

- B. **RESTRAINT:** Anchorages selected for restraint and travel restraint systems shall have a strength capable of sustaining static loads applied in the direction permitted by the system of at least:
  1. 4.5 kN (1,000 lbs) for non-certified anchorages, or
  2. Two times the foreseeable force for certified anchorages. When more than one restraint system is attached to an anchorage, the strength specified above shall be multiplied by the number of systems attached to the anchorage.

**2.5 LIFELINE REQUIREMENTS:** DBI/SALA rope grabs are to be used with DBI/SALA lifelines and lifeline subsystems. The lifeline used with the 5000335C and 5000336C rope grab is the 5/8-inch (16mm) diameter Polypropylene High Modulus Polyethylene Co-polymer assembly. See appropriate lifeline instructions for rope elongation factors. The following lifeline requirements must be followed:

**A. SIZE:** The rope grab is designed to be used only on 5/8-inch (16mm) diameter lifeline. Undersized rope may not allow the rope grab to lock properly and may cause excessive stopping distances. Oversized rope may impede rope grab mobility on the lifeline. It is recommended that lifeline diameter be 5/8 inch,  $\pm 1/32$  inch (16mm  $\pm 0.8$ mm).

**B. CONSTRUCTION:** Three-strand lay rope constructions are required. Braided, double braided, hollow braided, or other types of rope constructions must not be used. When selecting the lifeline, choose a rope with a firm lay. Inspect the lay of the rope by grasping it several feet from the end between the thumb and index finger. You should not be able to easily squeeze or flatten the rope. Untwisting should be difficult and the rope should spring back to its original shape.

**C. MATERIAL:** Rope grabs 5000335C and 5000336C were certified by CSA Z259.2.5 on the following rope:

Lifeline Rope Material	Rope Part Number
Polypropylene High Modulus Polyethylene Co-polymer	9508057

**D. STRENGTH:** Select a lifeline which, when terminated and installed, will retain a minimum strength of (5,000 lbs.) 22 kN per CSA Z259.2.5. Selection must account for strength reduction factors, such as sharp edges and degrading factors (i.e. chemicals).

**IMPORTANT:** CSA Z259.2.5 mandates the lower end of the lifeline have a termination that prevents the fall arrester from passing through that termination. When the line is installed, the bottom end shall also have a counterweight to provide stiffness. Knots shall not be used for load bearing end terminations.

**2.6 CONNECTING THE LANYARD:** The rope grab must be used with an E4 or E6 energy absorbing lanyard less than .75m (30 inches) in length to meet CSA Z259.2.5 fall arrest requirements. All lanyards must have a minimum breaking strength of 22.2 kN (5,000 lbs).

**2.7 BODY SUPPORT:** The recommended body support for fall arrest applications is a full body harness. When used in a restraint application, a body belt may be used.

### 3.0 OPERATION & USE

**WARNING:** Do not alter or intentionally misuse this equipment. Consult with DBI/SALA if using this equipment with components or subsystems other than those described in this manual. Some subsystem and component combinations may interfere with the operation of this equipment.

**WARNING:** Do not use this equipment if you are unable to tolerate the impact from a fall arrest. Age and fitness can seriously affect your ability to withstand a fall. Pregnant women and minors must not use this equipment.

- 3.1 BEFORE EACH USE OF THIS EQUIPMENT,** carefully inspect it to ensure that it is in good working condition. See Section 5.0 for inspection details. Do not use if inspection reveals an unsafe condition.
- 3.2 PLAN** your fall arrest or restraint system before starting your work. Consider all factors that affect your safety before, during, and after a fall. Refer to these and related subsystem component instructions, and state and federal safety regulations for guidance in planning your system. The following list gives some important points to consider when planning your system:

- A. ANCHORAGE:** Select a rigid anchorage point that is capable of supporting the required loads. See Section 2.4. The anchorage location must be carefully selected to reduce possible free fall and swing fall hazards and to avoid striking an object during a fall. For restraint systems the anchorage must be located such that no vertical free fall is possible. For fall arrest systems OSHA requires the anchorage be independent of the means suspending or supporting the user.
- B. FREE FALL:** Do not work above the anchorage level, increased fall distance will result. Personal fall arrest systems must be rigged such that the potential free fall is never greater than 1.8 m (5.9 feet). Restraint systems must be rigged such that there is no possible vertical free fall.
- C. FALL ARREST FORCES:** The fall arrest system will limit the fall arrest forces to 4kN (900 lbs) with an E4 lanyard and will limit the fall arrest forces to 6kN (1,350 lbs) with an E6 lanyard. Do not use a body belt for fall arrest.

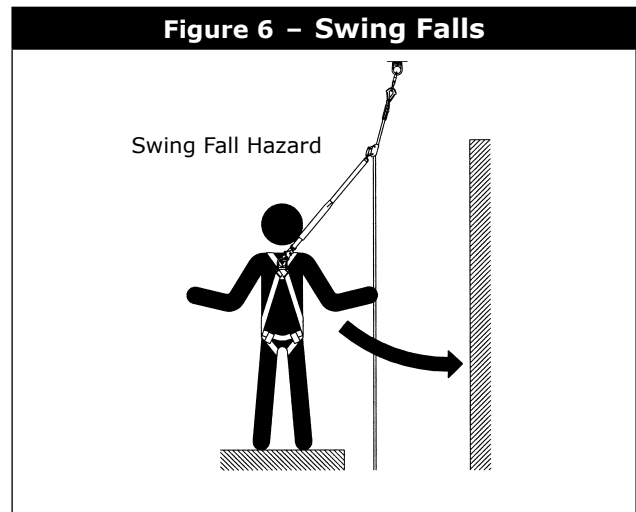

**DO NOT USE A BODY BELT FOR FALL ARREST.**

- D. SWING FALLS:** Swing falls occur when the anchorage point is not directly above the point where a fall occurs. The force of striking an object while swinging can be great and cause serious injury. Swing falls can be minimized by working as directly below the anchorage as possible. See Figure 6.
- E. FALL CLEARANCE:** Make certain enough clearance exists in your fall path to prevent striking an object. The amount of clearance needed is dependent upon the type of connecting subsystem used and anchorage location. See Figure 7 for estimating fall clearance.
- **Example - 1:** If the user has a Rope Value 'A' of 15.2m (50 ft), then the user will require a fall clearance of 6.2m (20.4 ft) with an *E4 Energy Absorber*. (See Figure 7.)
  - **Example - 2:** If the user has a Rope Value 'A' of 15.2m (50 ft), then the user will require a fall clearance of 6.8m (22.2 ft) with an *E6 Energy Absorber*. (See Figure 7.)
- F. SHARP EDGES:** Avoid working where parts of the system will be in contact with, or abrade against, unprotected sharp edges.
- G. RESCUE:** The user must have a rescue plan and the means at hand to implement it if a fall occurs.

- H. **AFTER A FALL:** Components which have been subjected to the forces of arresting a fall must be removed from service immediately and destroyed.
- I. **GENERAL USE CONSIDERATIONS:** Avoid working where lifeline may cross or tangle with that of another worker. Do not allow the lanyard to pass under arms or between legs. Do not clamp, tie, or otherwise prevent the rope grab lanyard connection handle from moving freely into the "locked" position.
- J. **SLOPED ROOFS:** Provisions must be made (warning lines, monitors, guardrails) to prevent swing falls from unprotected roof edges or corners. The rope grab should be connected to the body support using a locking carabiner (direct connection) or a short lanyard. If a lanyard is used for connecting to the rope grab, keep the length as short as possible, and never greater than .75m (30 inches). The lifeline must be protected from contact with sharp or abrasive edges and surfaces. The rope grab locking operation must not be hindered by interference with the roof or objects on the roof surface.

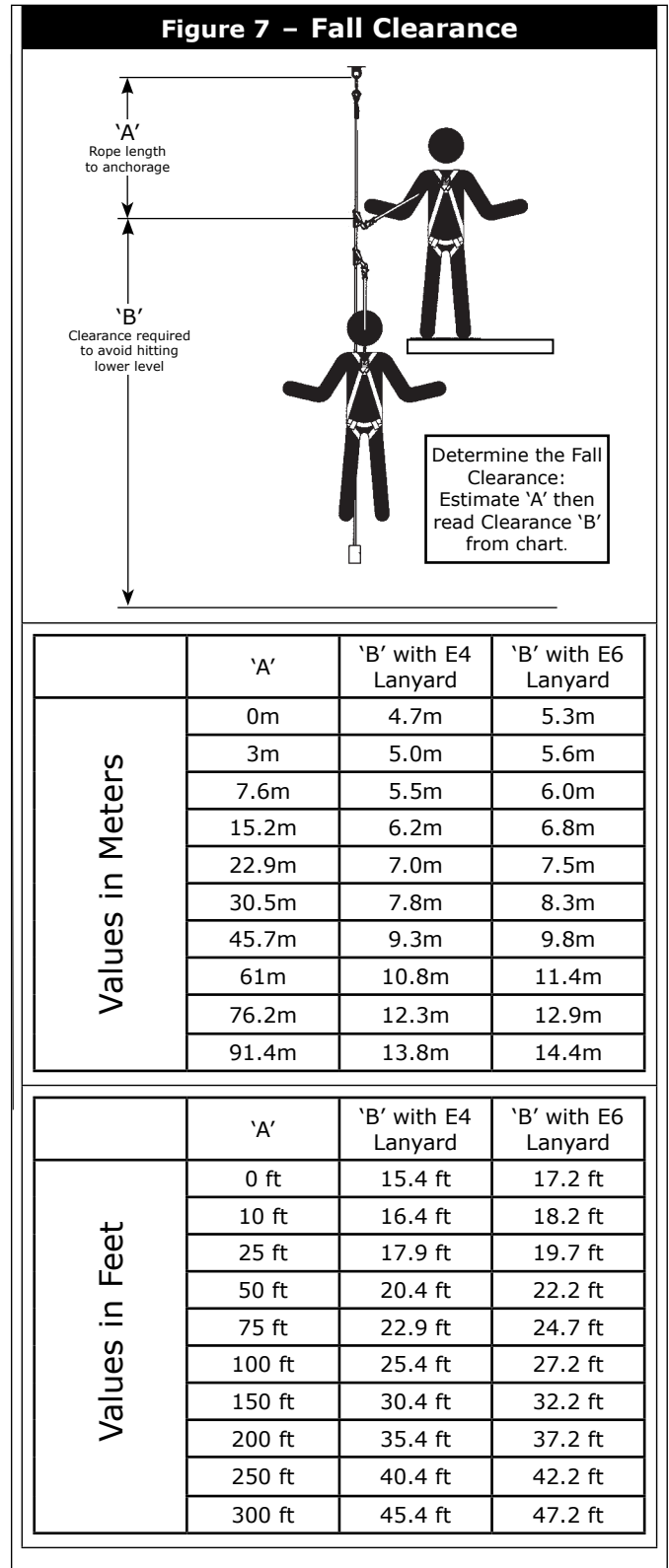

- K. **UNSTABLE SURFACES:** The rope grab is not suitable for use on unstable or slowly shifting materials, such as sand or grain.

### 3.3 ATTACHING THE ROPE GRAB TO THE LIFELINE:

- A.** Ensure the rope grab is in the "UP" position as indicated on the product label. The "UP" end of the rope grab must be oriented towards the anchorage when installed onto the lifeline. See Figure 8. NOTE: The rope grab hinge incorporates a lock which will prevent the hinge from closing if the rope grab is not held upright.

**Figure 8 – Attaching to Lifeline**

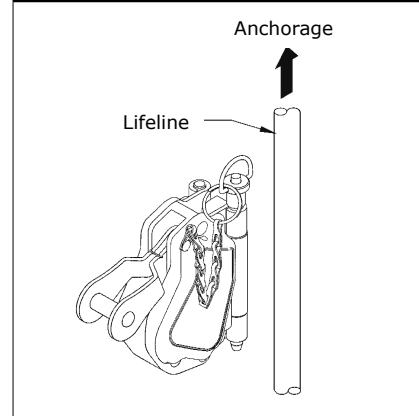

- B.** Remove the detent pin and open the hinged rope retainer. Raise the lanyard connection handle to full 'UP' position. Insert the lifeline into the rope grab. tSee Figure 9.

**Figure 9 – Attaching to Lifeline**

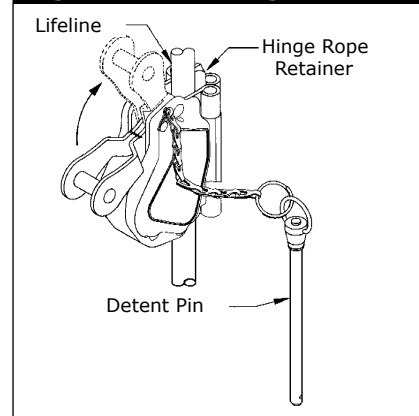

- C.** Close the hinged rope retainer and replace the detent pin. Ensure the detent pin is inserted all the way and is locked, (ball lock on end of pin). Confirm the detent pin is locked (ball-lock on end of pin). See Figure 10. Attach the lanyard to the lanyard connection handle.

**Figure 10 – Attaching to Lifeline**

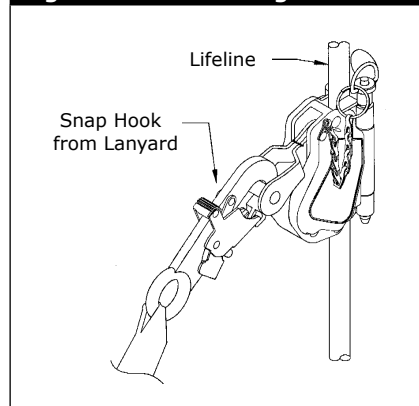

- D.** Test the operation of the rope grab by pulling down on the lanyard. You must not be able to pull the rope grab down the lifeline once the locking roller has fully engaged the lifeline.



### 3.4 POSITIONING THE ROPE GRAB ON THE LIFELINE:

- A. Using the lanyard connected to the rope grab, pull up slightly on the rope grab to release it from its current position. Lift the handle if necessary. Always keep a minimum of 4.7m (15.4 ft) of rope below the rope grab for fall clearance with an E4 Energy Absorber. Keep a minimum of 5.2m (17.2 ft) of rope below the rope grab for fall clearance with an E6 Energy Absorber.
- B. Using the connected lanyard, raise or lower the rope grab to the desired new position. Tension the lifeline to assure smooth motion of the rope grab on the lifeline. To tension the lifeline, extend 15-22m (50 to 75 feet) of lifeline below the rope grab, or secure the end of the lifeline at working or ground level, or use a six to ten pound counterweight. The method of tensioning used should be determined by job site conditions. NOTE: See Section 2.5 for recommendations and requirements.
- C. After moving the rope grab to a new position, position it at or above shoulder height to reduce possible free fall. Lock the rope grab at this position by pulling the lanyard connection handle to its full 'DOWN' position. The handle must be released before attempting to reposition the rope grab.
- D. Under special conditions, such as working on a moving platform, it is allowable to let the rope grab follow the worker as the platform is moved. The lanyard should be kept as short as possible and must not exceed .75m (30 inches) in length.

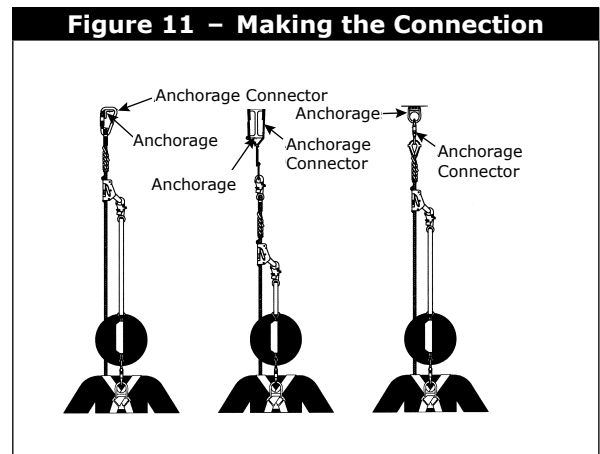

**WARNING:** Rope grab attachment and positioning instructions and procedures must be followed. Improper assembly could allow the rope grab to slip or not lock onto the lifeline in the event of a fall and may result in serious injury or death.

- 3.5 **CONNECTING TO ANCHORAGE OR ANCHORAGE CONNECTOR:** When attaching the lifeline or lifeline subsystem to the anchorage or anchorage connector, ensure the connector used (self locking snap hook) is fully engaged and locked onto the connection point. Ensure connections are compatible in size, shape, and strength. Refer to manufacturer's instructions for the anchorage connector and lifeline for further information. See Figure 11.
- 3.6 **CONNECTING TO THE BODY SUPPORT:** For fall arrest applications, connect to the dorsal D-ring located between the shoulders on the back of the full body harness. For restraint applications, the dorsal or frontal harness attachment may be used. If using a body belt for restraint applications connect to the D-ring opposite the restraining load. Ensure connections are compatible in size, shape, and strength. Refer to the body support manufacturer's instructions for more information on making connections. Under special conditions, such as working on a moving platform, it is allowable to let the rope grab follow the worker as the platform is moved. The lanyard should be kept as short as possible and must not exceed 0.75 m (30 inches) in length.
- 3.7 **CONNECTING TO THE ROPE GRAB:** When connecting an energy absorbing lanyard to the rope grab, attach the lanyard end (vs. the energy absorber end) to the rope grab to reduce possible interference with the operation of the rope grab by the energy absorber 'pack'. Some rope grab models may be supplied with a permanently attached lanyard or energy absorber. Do not attempt to attach additional lanyards or connectors to these subsystems. Ensure connections are compatible in size, shape, and strength. Ensure the connector attached to the rope grab allows the handle to rotate freely, and does not interfere with the rope grab operation.

### 3.8 USE OF LIFELINES: (See Lifeline User Instruction Manual for complete details)

- Always protect the lifeline if passing over or around sharp edges. Sharp edges can reduce rope strength by 70% or more.
- Keep lifelines clean.
- Avoid twisting or kinking lifelines when coiling or uncoiling
- Avoid using lifelines near acids or alkalines. If the lifeline is used around any chemical or compound, watch for signs of deterioration.
- Never use a knotted lifeline, knots can reduce rope strength by 50%.
- Always connect a counterweight to lifeline for stiffness as mandated per CSAZ259.2.5.
- Store lifelines properly. See Section 6.0.

**3.9 AFTER USE OF THE ROPE GRAB AND ITS SUBSYSTEM COMPONENTS:** Return it for cleaning or storage as described in Section 6.0.

### 4.0 TRAINING

**4.1 TRAINING:** The user, and the user's employer, must be trained in the correct use and care of this equipment. Both parties must be aware of the operating characteristics, application limits, and consequences of improper use of this equipment.

**IMPORTANT:** Training must be conducted without exposing the trainee to a fall hazard. Training should be repeated on a periodic basis.

### 5.0 INSPECTION

#### 5.1 FREQUENCY:

- A. Before each use, visually inspect the equipment per steps listed in Section 5.2, 5.3 and 5.4.
- B. The rope grab must be inspected by a *competent person*<sup>1</sup> other than the user at least annually. See Sections 5.2, 5.3 and 5.4 for guidelines. Record the results of each formal inspection in the inspection log found in back of manual.

**IMPORTANT:** If the rope grab has been subjected to fall arrest or impact forces, it must be immediately removed from service and destroyed.

**IMPORTANT:** Extreme working conditions (harsh environments, prolonged use, etc.) may require increasing the frequency of the inspections.

**5.2 INSPECTION STEPS FOR ROPE GRAB:** See Figure 1.

- Step 1.** Inspect the action of the locking roller, it should be free to travel the full length of the guide slots.
- Step 2.** Inspect the lanyard connection handle for freedom of motion. There should be no binding or sticking. Inspect for wear on the nose of the roller cam where it contacts the locking roller. The roller cam must push the locking roller into the rope.
- Step 3.** Inspect the handle spring. It should be in its correct place and undamaged.
- Step 4.** Inspect the detent pin. When pushed down and released, the top button should spring back up. The pin should easily slide through the rope grab body and hinge. The pin must lock in place when the button is released.
- Step 5.** The hinged rope retainer must pivot freely and close completely. Check that the gravity lock works freely. When the rope grab is held upside down, the gravity lock should drop down and prevent the hinge from fully closing. Inspect the hinge for signs of rope wear. There should be no dips or depressions worn into the rope channel.
- Step 6.** Inspect labels and markings. All labels and markings must be present and fully legible.
- Step 7.** Inspect the enclosure parts for cracks, distortion, or other damage.
- Step 8.** Inspect each system component or subsystem per associated manufacturer's instructions.
- Step 9.** Record the inspection date and results in the inspection log in back of manual.

**1 Competent Person:** One who is capable of identifying existing and predictable hazards in the surroundings or working conditions which are unsanitary, hazardous, or dangerous to employees, and who has authorization to take prompt corrective measures to eliminate them.

### 5.3 INSPECTION STEPS FOR LIFELINE: (See Lifeline User Instruction Manual for complete details)

- Step 1.** Lifeline hardware must not be damaged, broken, distorted, or have any sharp edges, burrs, cracks, worn parts, or corrosion. Ensure the connecting hooks work properly. Hook gates must move freely and lock upon closing.
- Step 2.** Inspect the rope for concentrated wear. The material must be free of frayed strands, broken yarns, cuts, abrasions, burns, and discoloration. The rope must be free of knots, excessive soiling, heavy paint buildup, and rust staining. Rope splices must be tight, with five full tucks, and thimbles must be held by the splice. Cracked or distorted rope thimbles may indicate that the lifeline has been impact loaded. Check for chemical or heat damage (indicated by brown, discolored, or brittle areas). Check for ultraviolet damage, indicated by discoloration and the presence of splinters and slivers on the rope surface. All of the above factors are known to reduce rope strength. Damaged or questionable ropes must be replaced.
- Step 3.** Inspect labels. All labels must be present and fully legible. Replace labels if illegible or missing.
- Step 4.** Record the inspection date and results in the inspection log found in the Lifeline User Instruction Manual.

**5.4 If inspection reveals a defective condition:** Remove the unit from service immediately and destroy, or contact a factory authorized service center for repair.

**IMPORTANT:** Do not attempt to alter, repair, or make substitutions to the rope grab or rope grab parts. Equipment found to be in defective condition must be removed from service. Repairs may only be performed by DBI/SALA or those authorized in writing to do so.

## 6.0 MAINTENANCE

- 6.1 CLEANING:** Clean the rope grab and lifeline with water and a mild soap solution. Wipe off hardware with a clean, dry cloth, and hang to air dry. Do not force dry with heat. An excessive buildup of dirt, paint, etc., may prevent the rope grab or lifeline from working properly, and in severe cases degrade the rope grab or rope to a point where it has weakened and should be removed from service. If you have any questions concerning the condition of the rope grab or lifeline, or have any doubt about putting them into service, contact DBI/SALA. See the Lifeline User Instruction Manual for specific maintenance details.
- 6.2 ADDITIONAL MAINTENANCE AND SERVICING PROCEDURES:**(Replacement parts) must be completed by a factory authorized service center. Authorization must be in writing. Do not attempt to disassemble the unit. See Section 5.1 for inspection frequency.
- 6.3 STORAGE:** Store the rope grab and lifeline in a cool, dry, clean environment out of direct sunlight. Avoid areas where chemical vapors may exist. Thoroughly inspect the rope grab and lifeline after any period of extended storage.

## **7.0 SPECIFICATION / PERFORMANCE DATA**

### **7.1 SPECIFICATIONS:**

- Material: All material used in the construction is certified to be new and free from defects.
- Construction: Riveted and welded with removable detent pin.
- Material Type:
  - Side Plates - 12 gauge, 316 Stainless Steel
  - Hinge - 6061-T6 Aluminum
  - Handle - 12 gauge, 316 Stainless Steel
  - Detent Pin - Stainless Steel
  - Roller - 303 Stainless Steel, nitrided
  - Rivets - Stainless Steel
  - Enclosure - Nylon
- Patent Number: U.S. 4,657,110, Can. 1,241,937, U.K. GB2,168,102B

### **7.2 PERFORMANCE DATA**

- Arrest Force: Designed for 4 kN (900 lbs) maximum arresting force with an E4 energy absorbing lanyard or 6 kN (1350 lbs) with an E6 energy absorbing lanyard.
- Maximum Capacity: 115 Kg (254 lbs) when using an E4 energy absorbing lanyard or 175 kg (386 lbs) when using an E6 energy absorbing lanyard.
- Requirements: Meets applicable local and federal standards.

**8.0 LABELS:** These labels and markings must be securely attached and fully legible:



Specification Label



Specification Label

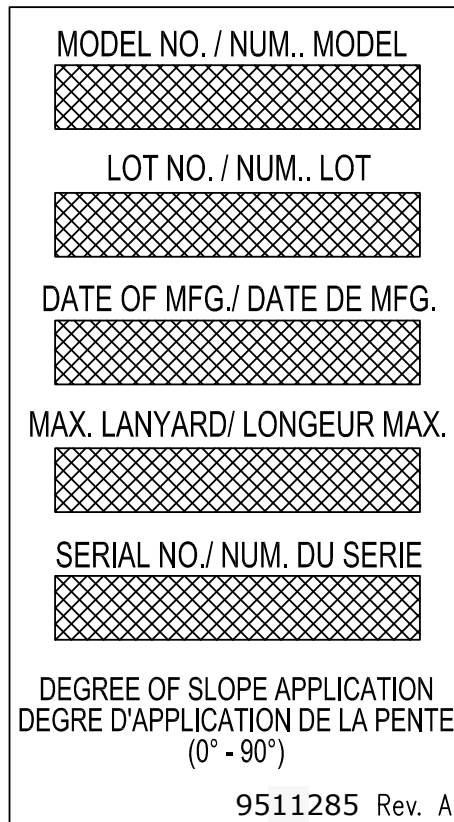

ID Label





## LIMITED LIFETIME WARRANTY

**Warranty to End User:** D B Industries, LLC dba CAPITAL SAFETY USA ("CAPITAL SAFETY") warrants to the original end user ("End User") that its products are free from defects in materials and workmanship under normal use and service. This warranty extends for the lifetime of the product from the date the product is purchased by the End User, in new and unused condition, from a CAPITAL SAFETY authorized distributor. CAPITAL SAFETY'S entire liability to End User and End User's exclusive remedy under this warranty is limited to the repair or replacement in kind of any defective product within its lifetime (as CAPITAL SAFETY in its sole discretion determines and deems appropriate). No oral or written information or advice given by CAPITAL SAFETY, its distributors, directors, officers, agents or employees shall create any different or additional warranties or in any way increase the scope of this warranty. CAPITAL SAFETY will not accept liability for defects that are the result of product abuse, misuse, alteration or modification, or for defects that are due to a failure to install, maintain, or use the product in accordance with the manufacturer's instructions.

CAPITAL SAFETY'S WARRANTY APPLIES ONLY TO THE END USER. THIS WARRANTY IS THE ONLY WARRANTY APPLICABLE TO OUR PRODUCTS AND IS IN LIEU OF ALL OTHER WARRANTIES AND LIABILITIES, EXPRESSED OR IMPLIED. CAPITAL SAFETY EXPRESSLY EXCLUDES AND DISCLAIMS ANY IMPLIED WARRANTIES OF MERCHANTABILITY OR FITNESS FOR A PARTICULAR PURPOSE, AND SHALL NOT BE LIABLE FOR INCIDENTAL, PUNITIVE OR CONSEQUENTIAL DAMAGES OF ANY NATURE, INCLUDING WITHOUT LIMITATION, LOST PROFITS, REVENUES, OR PRODUCTIVITY, OR FOR BODILY INJURY OR DEATH OR LOSS OR DAMAGE TO PROPERTY, UNDER ANY THEORY OF LIABILITY, INCLUDING WITHOUT LIMITATION, CONTRACT, WARRANTY, STRICT LIABILITY, TORT (INCLUDING NEGLIGENCE) OR OTHER LEGAL OR EQUITABLE THEORY.



Global Leader in Fall Protection

### USA

3833 SALA Way  
Red Wing, MN 55066-5005  
Toll Free: 800.328.6146  
Phone: 651.388.8282  
Fax: 651.388.5065  
solutions@capitalsafety.com

### Brazil

Rua Anne Frank, 2621  
Boqueirão Curitiba PR  
81650-020  
Brazil  
Phone: 0800-942-2300  
brasil@capitalsafety.com

### Mexico

Calle Norte 35, 895-E  
Col. Industrial Vallejo  
C.P. 02300 Azcapotzalco  
Mexico D.F.  
Phone: (55) 57194820  
mexico@capitalsafety.com

### Colombia

Compañía Latinoamericana de Seguridad S.A.S.  
Carrera 106 #15-25 Interior 105 Manzana 15  
Zona Franca - Bogotá, Colombia  
Phone: 57 1 6014777  
servicioalcliente@capitalsafety.com

### Canada

260 Export Boulevard  
Mississauga, ON L5S 1Y9  
Phone: 905.795.9333  
Toll-Free: 800.387.7484  
Fax: 888.387.7484  
info.ca@capitalsafety.com

### EMEA (Europe, Middle East, Africa)

*EMEA Headquarters:*  
5a Merse Road  
North Moons Moat  
Redditch, Worcestershire  
B98 9HL UK  
Phone: + 44 (0)1527 548 000  
Fax: + 44 (0)1527 591 000  
csgne@capitalsafety.com

### France:

Le Broc Center  
Z.I. 1re Avenue - BP15  
06511 Carros Le Broc Cedex  
France  
Phone: + 33 04 97 10 00 10  
Fax: + 33 04 93 08 79 70  
information@capitalsafety.com

### Australia & New Zealand

95 Derby Street  
Silverwater  
Sydney NSW 2128  
Australia  
Phone: +(61) 2 8753 7600  
Toll-Free : 1800 245 002 (AUS)  
Toll-Free : 0800 212 505 (NZ)  
Fax: +(61) 2 8753 7603  
sales@capitalsafety.com.au

### Asia

*Singapore:*  
69, Ubi Road 1, #05-20  
Oxley Bizhub  
Singapore 408731  
Phone: +65 - 65587758  
Fax: +65 - 65587058  
inquiry@capitalsafety.com

### Shanghai:

Rm 1406, China Venturetech Plaza  
819 Nan Jing Xi Rd,  
Shanghai 200041, P R China  
Phone: +86 21 62539050  
Fax: +86 21 62539060  
inquiry@capitalsafety.cn

[www.capitalsafety.com](http://www.capitalsafety.com)

